

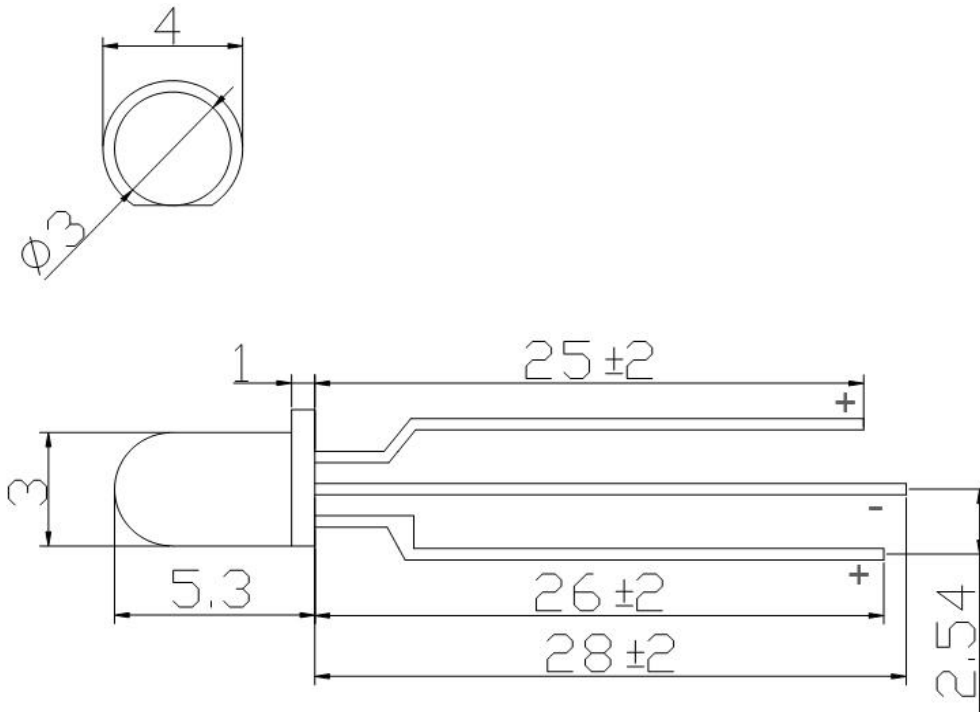

3mm Bi-Color Red / Blue LED Common Cathode Water Clear Lens

Part Number: RDR3-2URUBC-CC

■ Package Dimensions(mm)



Notes:

1. All dimension units are millimeters.
2. All dimension tolerance is ± 0.2 mm unless otherwise noted.
3. An epoxy meniscus may extend about 1.5mm down the leads.
4. Burr around bottom of epoxy may be 0.5mm max.

Synopsi s: 3mm Round Type
Bi-Color LED Lamp

Water Clear Lens



3mm Bi-Color Red / Blue LED Common Cathode Water Clear Lens

Part Number: RDR3-2URUBC-CC							
■ Typical Electrical & Optical Characteristics (Ta = 25°C)							
Emitting Color	ITEMS	SYMBOL	CONDITION	MIN.	TYP.	MAX.	UNIT
Red	Forward Voltage	VF	IF = 20mA	1.8		2.4	V
	Luminous Intensity	IV	IF = 20mA	800		1000	mcd
	Dominant Wavelength	λ_D	IF = 20mA	620		630	nm
Blue	Forward Voltage	VF	IF = 20mA	2.8		3.4	V
	Luminous Intensity	IV	IF = 20mA	1500		2000	mcd
	Dominant Wavelength	λ_D	IF = 20mA	460		470	nm
Reverse Current		IR	VR = 5V	---	---	10	μ A
50% Power Viewing Angle		20½	IF = 20mA		25		deg
■ Absolute Maximum Ratings at (Ta = 25°C)							
ITEMS		SYMBOL	ABSOLUTE MAXIMUM RATING			UNIT	
Peak Forward Current		IFP	100			mA	
Continuous Forward Current		IL	20			mA	
Reverse Voltage		VR	5			V	
Power Dissipation		PD	115			mW	
Operation Temperature		Topr	-40 ~ +80			°C	
Storage Temperature		Tstg	-40 ~ +80			°C	
Lead Soldering Temperature		Tsol	Max.260°C for 5 sec Max.				

IFP Conditions: Pulse Width \leq 10msec duty \leq 1/10

Tsol Conditions: 4mm from the base of the epoxy bulb



3mm Bi-Color Red / Blue LED Common Cathode Water Clear Lens

Part Number: RDR3-2URUBC-CC

■ Spatial Distribution

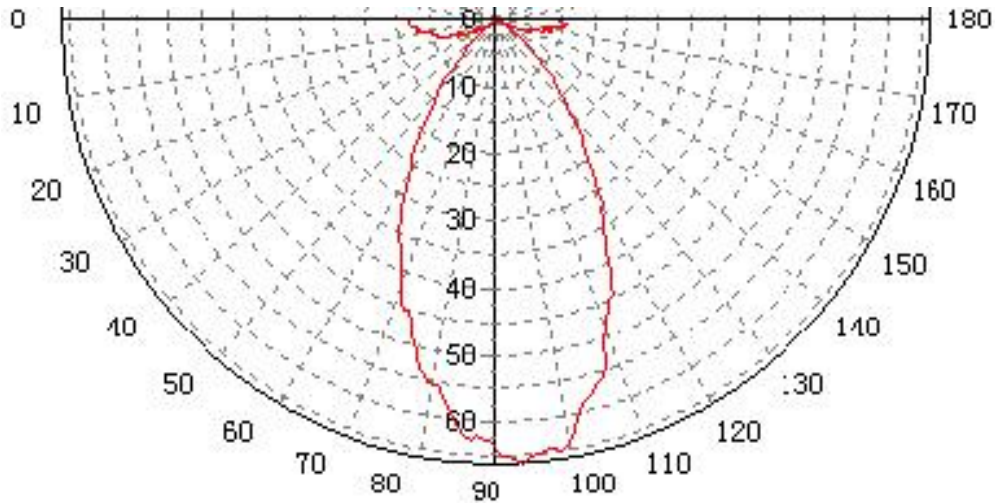

■ Reliability Performance

Test Classification	Test Item	Test Conditions	Test Duration	Sample Size	Standard
Life Test	Life Test	Ta=25°C±5°C, IF=20mA	1000小时(hrs)	10PCS	
Environment Test	Thermal Shock Test	-10°C±5°C←→+100°C±5°C 5min. 10sec. 5min.	100循环(cycles)	10PCS	
	Temperature Cycle Test	-55°C±5°C←→+85°C±5°C 30min. 5min. 30min.	100循环(cycles)	10PCS	
	High Temperature & High Humidity Test	Ta=85°C±5°C RH =85%±0.5 %RH	240小时(hrs)	10PCS	
	High Temperature Storage	Ta=100°C±5°C	1000小时(hrs)	10PCS	
	Low Temperature Storage	Ta=-55°C±5°C	1000小时(hrs)	10PCS	
Environment Te	Resistance to Soldering Heat	Ta=260°C±5°C	5 秒(sec.)	10PCS	
	Lead Integrity	负荷2.5 牛顿(0.25 千克) 0° ~ 90° ~ 0°	3 回合(times)	10PCS	



3mm Bi-Color Red / Blue LED Common Cathode Water Clear Lens

Part Number: RDR3-2URUBC-CC

■ Typical Optical / Electrical Characteristics Curves

(Ta=25°C Unless Otherwise Noted)

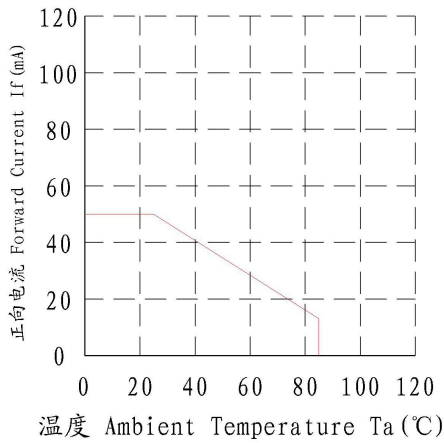

电流-电压曲线
Current-Voltage Curve

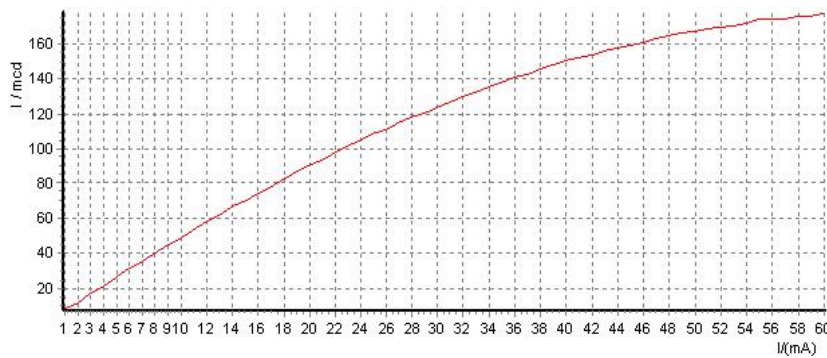

电流-光强曲线
Current-Luminous intensity Curve

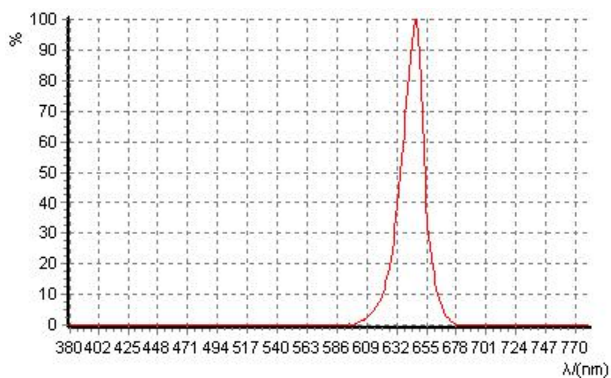

相对光谱分布曲线 (红色)
Relative Spectral Distribution Curve (Red)

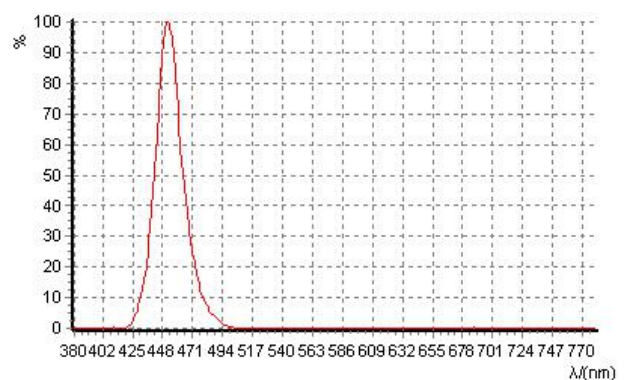

相对光谱分布曲线 (蓝色)
Relative Spectral Distribution Curve (Blue)



3mm Bi-Color Red / Blue LED Common Cathode Water Clear Lens

Part Number: RDR3-2URUBC-CC

1. 应用

此LED可使用于一些普通的电子设备，例如办公设备，通信设备、房屋装饰，若LED用在一些可靠性要求较高的情况下，如航空运输，交通控制及医辽器械时，一定需参考销售提供之资料进行使用。

2. 贮存

贮存LED的环境，温度不超过30℃，相对湿度不超过70%。建议LED在原包装箱里日期不超过三个月进行使用，如果需加长贮存时间，建议放在干燥箱内，并加放干燥剂，或者充入氮气。

3. 清洗

当用化学品清洗胶体时必须特别小心，因为有些化学品对胶体表面有损伤并引起褪色，如三氯乙烯、丙酮等。可用乙醇擦拭、浸渍，时间在常温下不超过3分钟。

4. 引脚装配

- (1) 必需离胶体2毫米才能折弯支架。
- (2) 支架成形必须用夹具或由专业人员来完成。
- (3) 支架成形必须在焊接前完成。
- (4) 支架成形需保证引脚和间距与线路板上的一致。
- (5) 焊接必须在正常温度下进行，当LED正常焊接到PCB板上后，应尽量避免在LED引脚处施加机械压力。

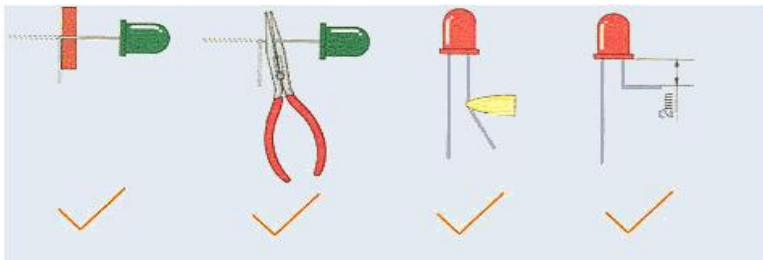

5. 焊接

当焊接时，必需在胶体底部2mm以下进行焊接，在焊接时，应尽力避免浸渍LED胶体，在刚焊接完后，应避免在引脚上加外力或者摇动LED胶体。

推荐的焊接条件

烙铁焊接		波峰焊	
焊接温度	260℃ Max	预热温度	100℃ Max
焊接时间	5 Sec. Max	预热时间	60sec. Max
	(one time only)	焊接温度	260℃ Max
		焊接时间	10sec. Max

过高的焊接温度和长时间的焊接会导致LED变形和失效

6. 驱动方式

LED的当前驱动方式

若LED为多颗并联时，建议采用线路A，在每颗LED处加一限流电阻，以保证LED之亮度一致。

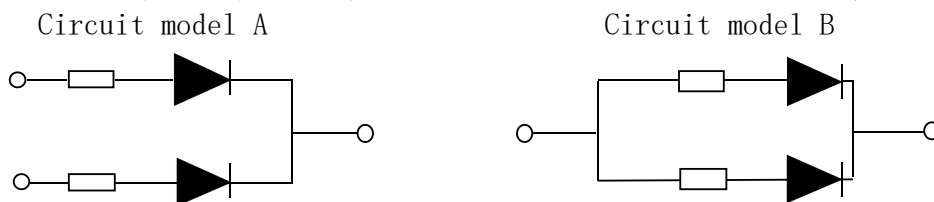

7. 静电防护

静电和电流的急剧升高将会对LED产生损害，KENTO系列产品使用时请使用防静电装置，如防护带和手套。

注意：使用时人体放电模式HBM<1000V；机器放电模式<100V。