



Technical Data Sheet

Product Name: 1010 RGB SMD Chip LED

Part Number: RD1010-653RGBBD-S65

Customer: _____

Customer PN: _____

Version No.: A.4

Date: July 12th, 2015

<h2>Customer Approval</h2>		

Instituted By: _____ **Checked By:** _____ **Approved By:** _____

Shenzhen RigDoo Optoelectronics Co., Ltd.

E-mail: info@rigdoo.com

Http://www.rigdoo.com



RigDoo Technical Data Sheet

Part No. : RD1010-653RGBBD-S65

Version

A.4

Issued date

July 12th, 2015

Page

1 of 9

1. Features

- Package (L/W/H) : 1.0×1.0×0.64 mm
- Color : Ultra Bright RGB Full Color
- Lens: Black Diffused Flat Mold
- EIA STD Package
- Meet ROHS, Green Product
- Compatible With SMT Automatic Equipment
- Compatible With Infrared Reflow Solder Process

2. Package Profile & Soldering PAD Suggested

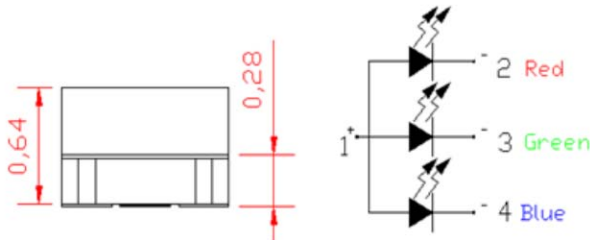
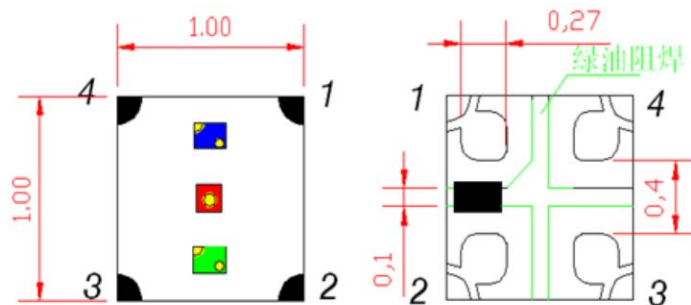

Recommended Solder pad Design

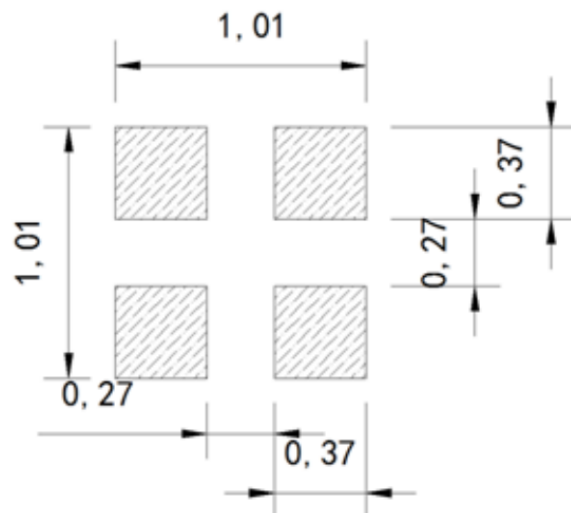

- Notes: 1. All dimensions are in millimeters ;
2. Tolerance is ± 0.10 mm unless otherwise noted.

3. Soldering Profile Suggested

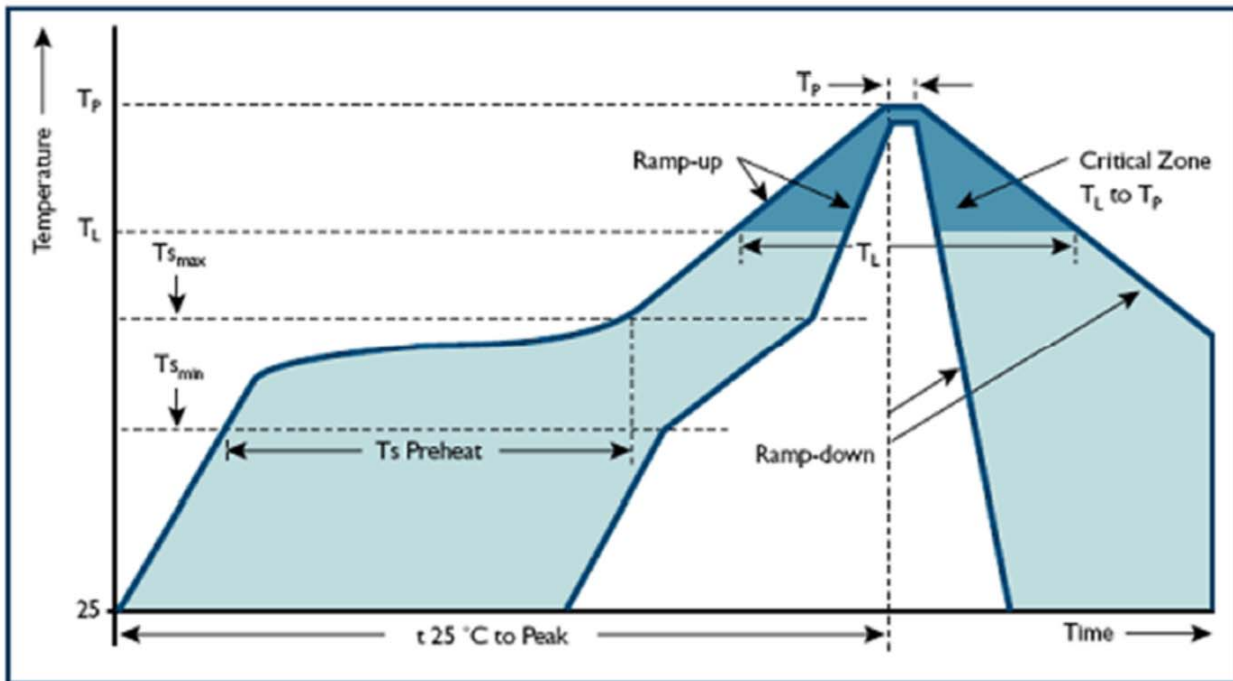

3.1 For Lead Solder

Temperature rising slope $T_{s_{max}}$ to $T_P=4\text{ °C Max}$

Preheating temperature $T_{s_{min}}=100\text{ °C} \sim 150\text{ °C}$

Warm-up time $T_{s_{min}}$ to $T_{s_{max}}=100\text{ s Max}$

Temperature falling slope 6 °C/s Max

Peak temperature $T_P=230\text{ °C Max}$

At Peak temperature $\pm 5\text{ °C}$, **time not exceed 10s**

Temperature higher than 183 °C , **time not exceed 80s**

3.2 For Lead Free Solder

Temperature rising slope $T_{s_{max}}$ to $T_P=4\text{ °C Max}$

Preheating temperature $T_{s_{min}}=150\text{ °C} \sim 200\text{ °C}$

Warm-up time $T_{s_{min}}$ to $T_{s_{max}}=100\text{ s Max}$

Temperature falling slope 6 °C/s Max

Peak temperature $T_P=245\text{ °C Max}$

At Peak temperature $\pm 5\text{ °C}$, **time not exceed 10s**

Temperature higher than 217 °C , **time not exceed 80s**



RigDoo Technical Data Sheet

Part No. : RD1010-653RGBBD-S65

Version

A.4

Issued date

July 12th, 2015

Page

3 of 9

4. Absolute Maximum Ratings At Ta=25°C

Parameter	Symbol	Rating		Unit
Power Dissipation	Pd	B	30	mW
		R	45	
		G	45	
Peak Forward Current (1/10 Duty Cycle, 0.1ms Pulse Width)	IFP	B	50	mA
		R	60	
		G	50	
DC Forward Current	IF	B	10	mA
		R	20	
		G	15	
Reverse Voltage	VR	B	5	V
		R	5	
		G	5	
Operating Temperature Range	Topr	-25°C ~ + 80°C		
Storage Temperature Range	Tstg	-40°C ~ + 80°C		
Soldering Condition	Tsol	Reflow soldering : 245°C For 5 Seconds		
Junction Temperature	Tj	110	°C	



RigDoo Technical Data Sheet

Part No. : RD1010-653RGBBD-S65

Version

A.4

Issued date

July 12th, 2015

Page

4 of 9

5. Electrical Optical Characteristics At Ta=25°C

Parameter	Symbol	Color	Min.	Typ.	Max.	Unit	Test Condition
Luminous Intensity	IV	B		25		mcd	IF = 10mA
		R		45			IF = 10mA
		G		110			IF = 10mA
Dominant Wavelength	λ_d	B	465	---	475	nm	IF = 10mA
		R	618	---	625		IF = 10mA
		G	515	---	530		IF = 10mA
Peak Wavelength	λ_p	B	---	---	---	nm	IF = 10mA
		R	---	---	---		IF = 10mA
		G	---	---	---		IF = 10mA
Spectral Line Half-Width	$\Delta\lambda$	B	---	---	---	nm	IF = 10mA
		R	---	---	---		IF = 10mA
		G	---	---	---		IF = 10mA
Forward Voltage	VF	B	2.5	---	3.1	V	IF = 10mA
		R	1.8	---	2.2		IF = 10mA
		G	2.4	---	3.1		IF = 10mA
Reverse Current	IR	B	---	---	1	uA	VR=10V
		R	---	---	1		
		G	---	---	1		
Viewing Angle	2 θ 1/2	---	---	115	---	deg	IF = 10mA

- Notes: 1. Luminous intensity is measured with a light sensor and filter combination that approximates the CIE eye-response curve.
2. θ 1/2 is the off-axis angle at which the luminous intensity is half the axial luminous intensity.
3. The dominant wavelength, λ_d is derived from the CIE chromaticity diagram and represents the single wavelength which defines the color of the device.



RigDoo Technical Data Sheet

Part No. : RD1010-653RGBBD-S65

Version

A.4

Issued date

July 12th, 2015

Page

5 of 9

6. Typical Electrical-Optical Characteristics Curves

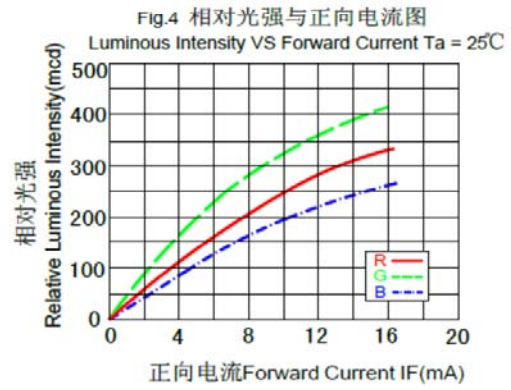
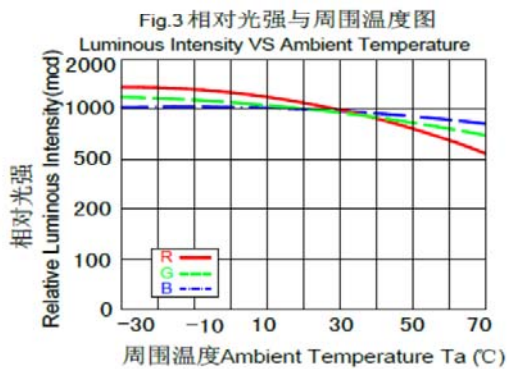
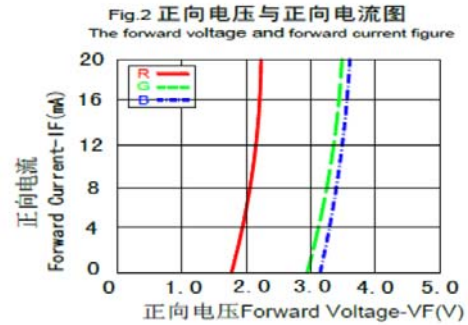
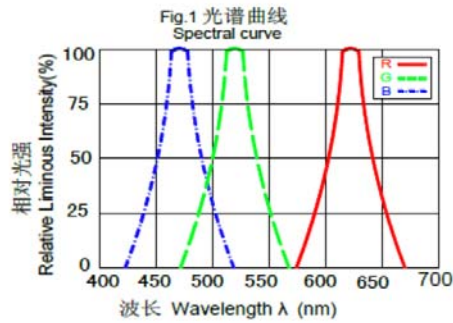

Fig.5 正向电流与温度图
Forward current and temperature

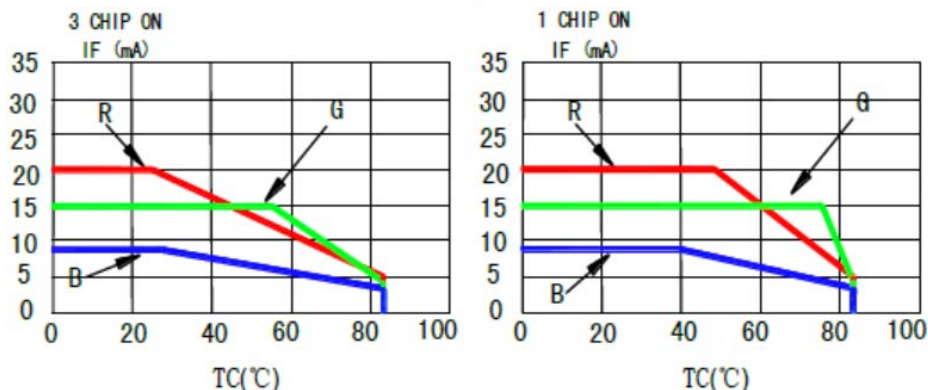
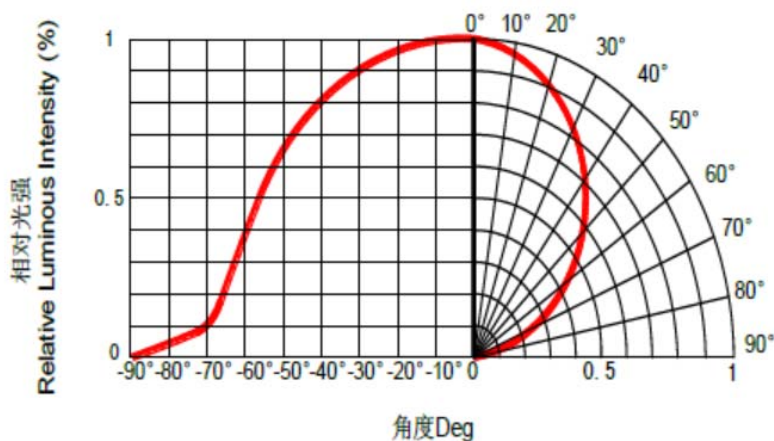

Fig.6 光强分布特性曲线
The intensity distribution curve



7. Label explanation

CAT: Luminous Intensity Rank (unit : mcd)
 HUE: Dominant Wavelength Rank (unit : nm)
 REF: Forward Voltage Rank (unit : V)

Rank Tolerance:

- Luminous Intensity: $\pm 11\%$
- HUE: $\pm 1\text{nm}$
- Forward Voltage: $\pm 0.02\text{V}$

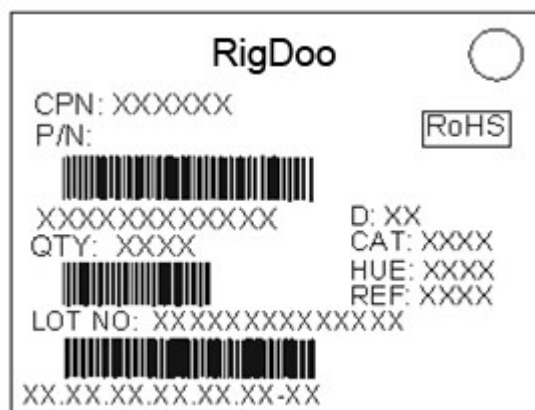

8. Carrier Tape Specifications



RigDoo Technical Data Sheet

Part No. : RD1010-653RGBBD-S65

Version

A.4

Issued date

July 12th, 2015

Page

7 of 9

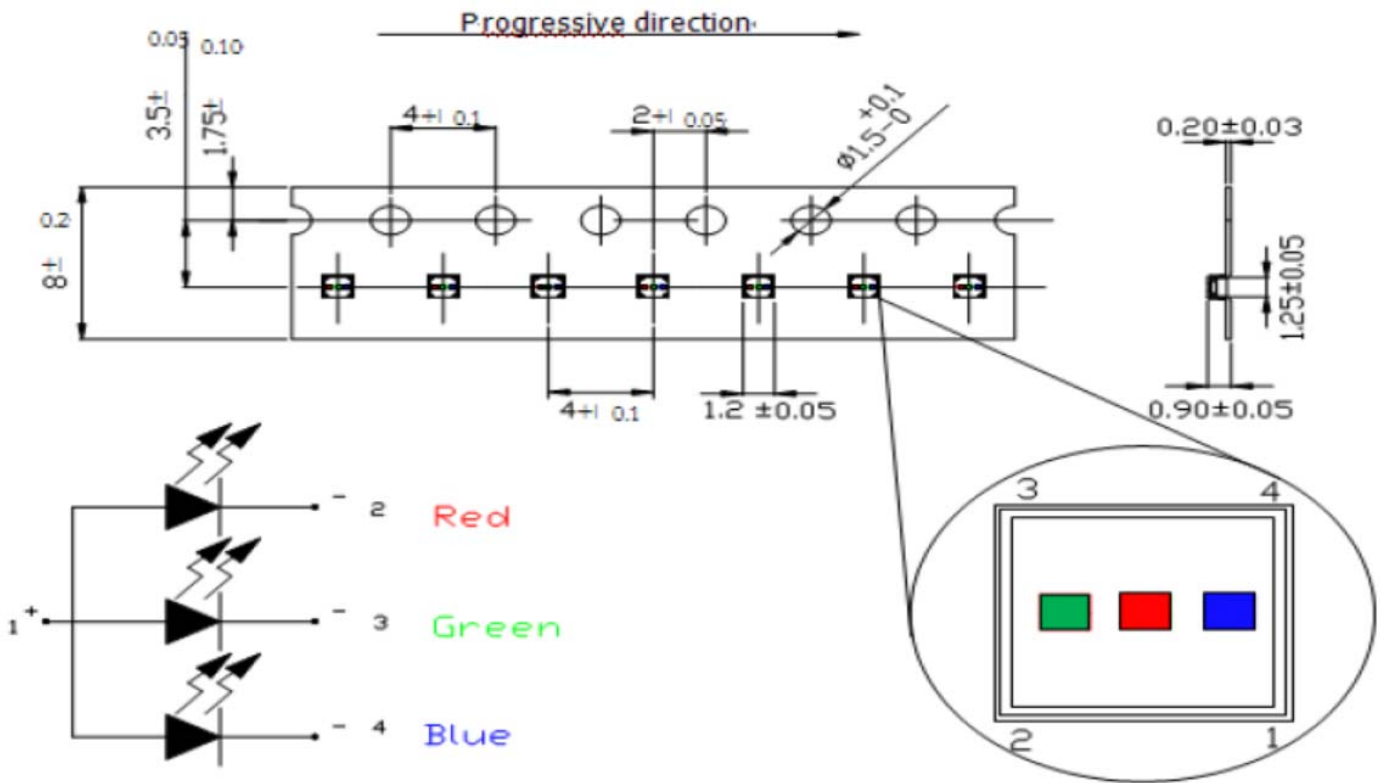

9. Reliability Test



RigDoo Technical Data Sheet

Part No. : RD1010-653RGBBD-S65

Version

A.4

Issued date

July 12th, 2015

Page

8 of 9

Classification	Test Item	Test Condition	Reference Standard	Reference Standard
Endurance Test	Operation Life	Ta= Under Room Temperature As Per Data Sheet Maximum Rating	1000HRS (-24HRS,+72HRS)*@10mA	MIL-STD-750D:1026 MIL-STD-883D:1005 JIS C 7021:B-1
	High Temperature, High Humidity Storage	IR-Reflow In-Board, 2 Times Ta= 85±5°C,RH= 85%	1000HRS±2HRS	JESD22-A101
	High Temperature Storage	Ta= 105±5°C	1000HRS (-24HRS,+72HRS)	MIL-STD-883D:1008 JIS C 7021:B-10
	Low Temperature Storage	Ta= -55±5°C	1000HRS (-24HRS,+72HRS)	JIS C 7021:B-12
Environmental Test	Temperature Cycling	105°C ~ 25°C ~ -55°C ~ 25°C 30mins 5mins 30mins 5mins	10 Cycles	MIL-STD-202F:107D MIL-STD-750D:1051 MIL-STD-883D:1010 JIS C 7021:A-4
	Thermal Shock	IR-Reflow In-Board, 2 Times 85 ± 5°C ~ -40°C ± 5°C 10mins 10mins	10 Cycles	MIL-STD-202F:107D MIL-STD-750D:1051 MIL-STD-883D:1011
	Solder Resistance	T.sol= 260 ± 5°C	10 ± 1secs	MIL-STD-202F:210A MIL-STD-750D:2031 JIS C 7021:A-1
	IR-Reflow Normal Process	Ramp-up rate(183°C to Peak) +3°C/ second max Temp. maintain at 125(±25)°C 120 seconds max Temp. maintain above 183°C 60-150 seconds Peak temperature range 235°C+5/-0°C Time within 5°C of actual Peak Temperature (tp) 10-30 seconds Ramp-down rate +6°C/second max	-----	MIL-STD-750D:2031.2 J-STD-020C
	IR-Reflow Pb Free Process	Ramp-up rate(217°C to Peak) +3°C/ second max Temp. maintain at 175(±25)°C 180 seconds max Temp. maintain above 217°C 60-150 seconds Peak temperature range 260°C+0/-5°C Time within 5°C of actual Peak Temperature (tp) 20-40 seconds Ramp-down rate +6°C/second max	-----	MIL-STD-750D:2031.2 J-STD-020C
Solderability	T.sol= 235 ± 5°C Immersion rate 25±2.5 mm/sec Coverage ≧ 95% of the dipped surface	Immersion time 2±0.5 sec	MIL-STD-202F:208D MIL-STD-750D:2026 MIL-STD-883D:2003 IEC 68 Part 2-20 JIS C 7021:A-2	